



REFRIGERATION

SERVING THE FOOD INDUSTRY SINCE 1951

36-INCH CURVED GLASS REFRIGERATED FLOOR SHOWCASE

Item: 44387 Model: RS-CN-0271



OMCAN'S CURVED GLASS FLOOR REFRIGERATED DISPLAY CASE

provides an economical solution for displaying your products. Features an exterior tempered glass finish and interior led lighting, this refrigerated showcase also has an automatic defrost system and fan cooling system. Easy to use and clean. Ideal for deli shops, cafes, and sandwich shops.



WARRANTY
PARTS AND LABOR



SHIPPED ON PALLET



Authorized Dealer

REFRIGERATION

36-INCH CURVED GLASS REFRIGERATED FLOOR SHOWCASE



FEATURES

- Digital temperature controller and display
- Adjustable glass shelves with chrome-plated sidings
- Four-sided double glass
- 4 casters with 2 brakes
- Ventilated cooling system
- Automatic defrost
- Stainless steel base



TECHNICAL DRAWINGS AND DIMENSIONS

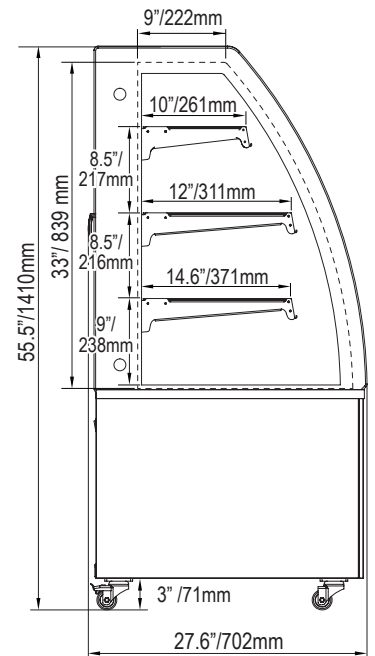
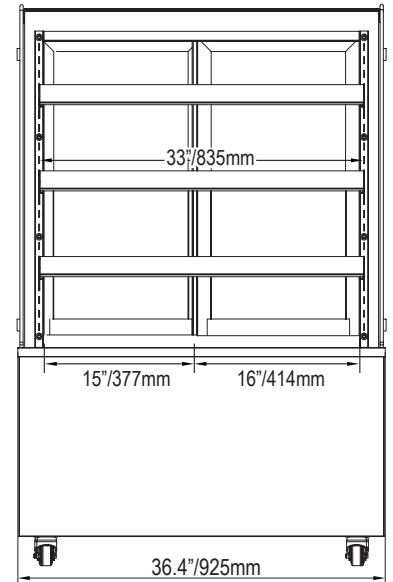

TECHNICAL SPECIFICATIONS

ITEM NUMBER	44387	TYPE OF CLIMATE	4
MODEL	RS-CN-0271	RATED CURRENT	7.1A
POWER	600W	ELECTRICAL	110V / 60Hz / 1Ph
CAPACITY	310L / 10.95 cu. ft.	SHELF SIZE	36.8" x 12" / 935 x 311mm 36.8" x 14" / 935 x 361mm
NUMBER OF SHELVES	3	INNER DIMENSIONS	33" x 23" x 32.7" / 845 x 585 x 830mm
LAMP POWER	23W	NET DIMENSIONS	36" x 26.8" x 55.5" / 925 x 680 x 1410mm
TEMPERATURE RANGE	0-12°C / 32-54°F	GROSS DIMENSIONS	41" x 31" x 65" / 1045 x 785 x 1655mm
REFRIGERANT	R290	NET WEIGHT	322 lbs / 146 kgs
BLOWING GAS	Front	GROSS WEIGHT	386 lbs / 175 kgs

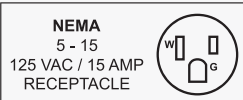

OMCAN INC.

Telephone: 1-800-465-0234
 Fax: (905) 607-0234
 Email: sales@omcan.com
 Website: www.omcan.com



Follow us to keep up to date with the latest news and offers



2018.E.O.E